

ST700BR-B

Real Microwave Presence Sensor





Instruction

Welcome to use ST700BR-B Real Microwave Presence Sensor!

The product adopts microwave sensor mould with high-frequency electro-magnetic wave (24GHz) and integrated circuit. It detects human breath, as long as people are present, the lights will remain on. When people leave, the lights will go out. It gathers automatism, convenience, safety, saving-energy and practical functions.

SPECIFICATION

Voltage	220-240V/AC	Detection Range	360°
Power Frequency	50/60Hz	Detection Distance	2-6m(diameter) adjustable
Time Delay	Min.10sec±3sec Max.12min±1min	Ambient Light	<3-2000LUX (adjustable)
Rated Load	Max.2000W  1000W 	HF System	24GHz CW radar, ISM band
Transmission Power	<10mW	Installation Height	2-4m

FUNCTION

- Can identify day and night: It can work in the daytime and at night when it is adjusted on the "sun" position (max). It can work in the ambient light less than 3LUX when it is adjusted on the "3" position (min). As for the adjustment pattern, please refer to the testing pattern.
- SENS adjustable: It can be adjusted according to using location. The detection distance could be only 2m and high sensitivity could be 6m which fits for large room.
- Time-Delay is added continually: When it receives the second induction signals within the first induction, it will restart to time from the moment.
- Time-Delay is adjustable. It can be set according to the consumer's desire. The minimum time is 10sec±3sec. The maximum is 12min±1min.

CONNECTION

 **WARNING** Danger of death through electric shock!



- Must be installed by professional electrician.
- Disconnect power source.
- Cover or shield any adjacent live components.
- Ensure device cannot be switched on.
- Check power supply is disconnected.

INSTALLATION (see the diagram)

- Switch off the power.
- Please move the upper cover with anti-clockwise whirl as per the diagram on the right.
- Connect the power and the load according to the connection-wire diagram.
- Fix the bottom on the selected position with the inflated screw.
- Install back the upper cover on the sensor, then you could switch on the power and test it.

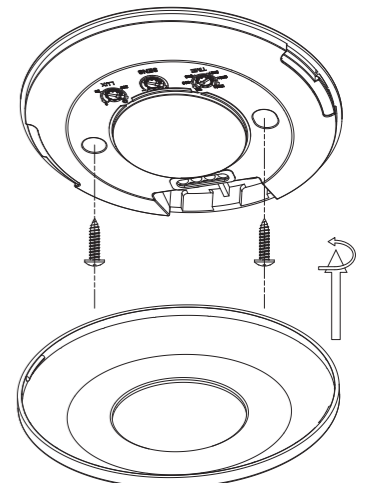

CONNECTION-WIRE DIAGRAM

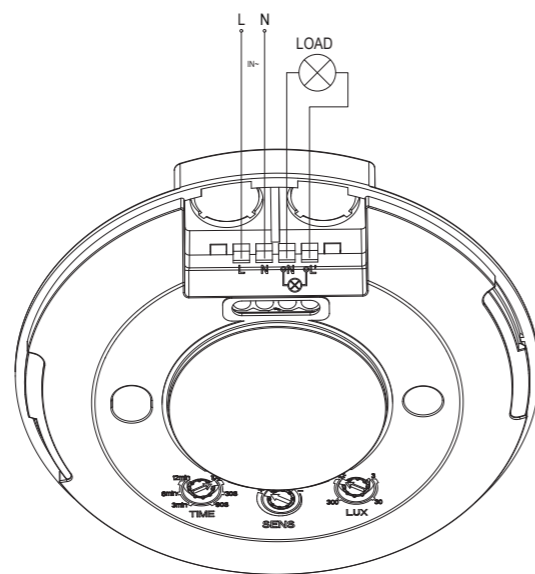
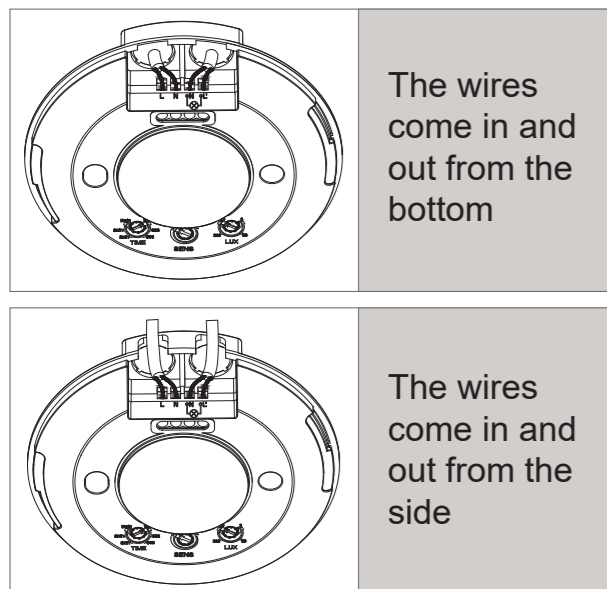

SENSOR INFORMATION

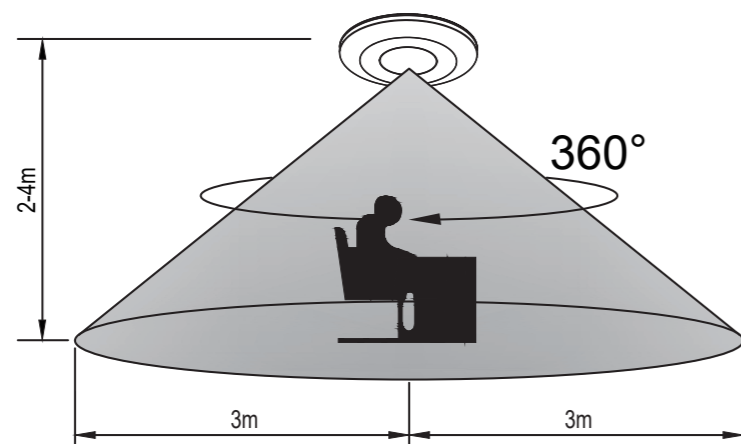

Height of installation:2-4m

TEST

- Turn the TIME knob anti-clockwise on the minimum (10s). Turn the SENS knob clockwise on the maximum (+). Turn the LUX knob clockwise on the maximum (sun).
- When you switch on the power, the light will be on at once. And 10sec±3sec later the light will be off automatically. Then if the sensor receives induction signal again, it can work normally.
- When the detection distance is less than 3m, it can detect human breathing and keep the lamp on continuously. When the detection distance is more than 3m and then the lamp will be off after the set time if there is no other movement.

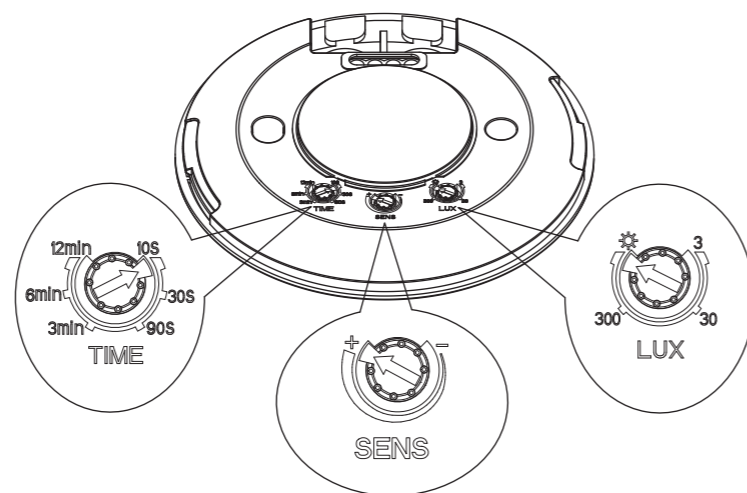

- When the detection distance is 3-4.5m, it will be worked as a normal microwave sensor and detects human movement automatically.
- When the sensor receives the second induction signals within the first induction, it will restart to time from the moment.
- Turn LUX knob anti-clockwise on the minimum (3). If the ambient light is less than 3LUX (darkness), the inductor load could work when it receives induction signal.

Note: When testing in daylight, please turn LUX knob to ☀ (SUN) position, otherwise the sensor could not work!

NOTES

- Electrician or experienced human can install it.
- Can not be installed on the uneven and shaky surface.
- In front of the sensor there shouldn't be obstructive object affecting detection.
- Avoid installing it near the metal and glass which may affect the sensor.
- For your safety, please don't open the case if you find hitch after installation.

SOME PROBLEM AND SOLVED WAY

- **The load don't work:**
 - a. Check the power and the load.
 - b. Whether the indicator light is turned on after sensing? If yes, please check load.
 - c. If the indicator light does not turn on after sensing, please check if the working light corresponds to the ambient light.
 - d. Please check if the working voltage corresponds to the power source.
- **The sensitivity is poor:**
 - a. Please check the ambient temperature.
 - b. Please check if the signals source is in the detection fields.
 - c. Please check the installation height.
- **The sensor can't shut automatically the load:**
 - a. If there are continual signals in the detection fields.
 - b. If the time delay is set to the longest.
 - c. If the power corresponds to the instruction.