

CMI

 ES (2)

 PT (3)

 IT (4)

 DE (5)

 EN (6)

Instalación carril integrable/trimless

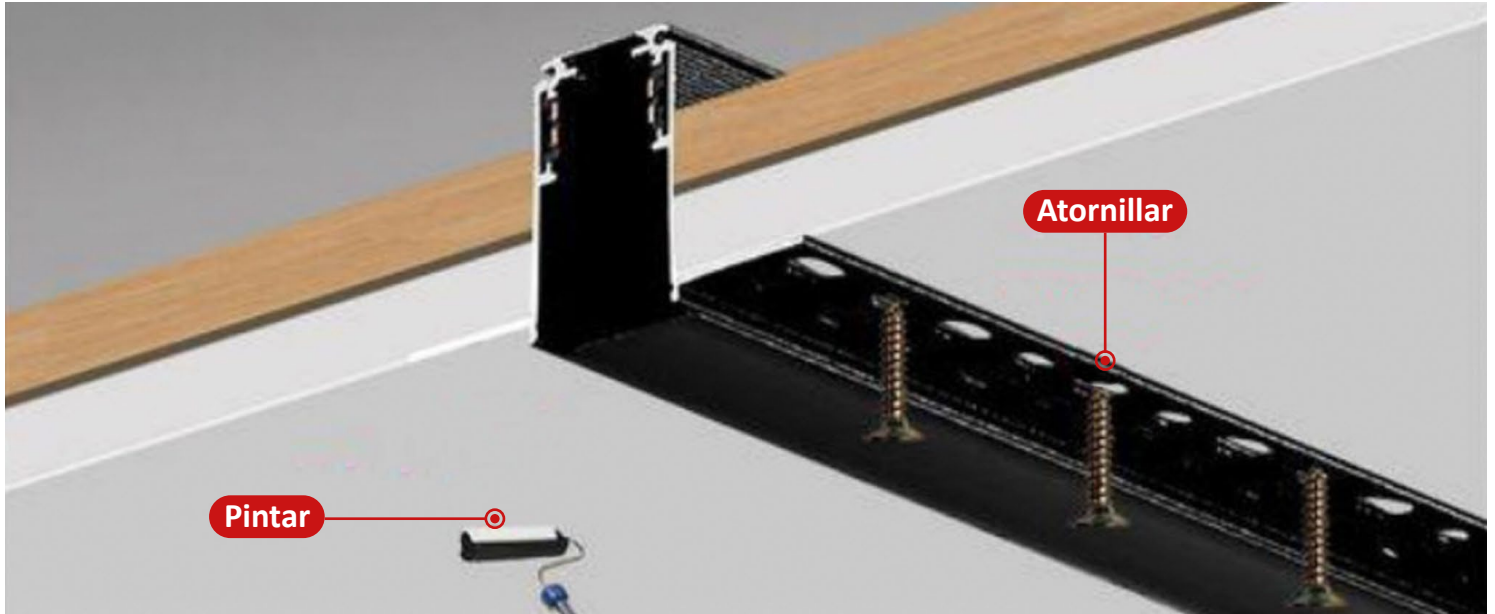

- 1 Realizar un hueco en el pladur de al menos 35mm de ancho. Tener en cuenta que se requiere un espacio mínimo de 5,5cm entre el techo o pared y el pladur.

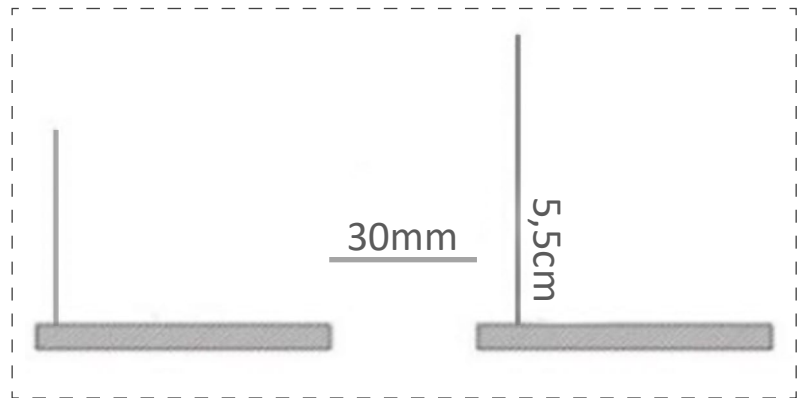

- 2 Colocar el carril dentro del hueco y atornillar hasta que quede firmemente ajustado. Luego colocar pasta de agarre o de juntas, lijar y pintar.

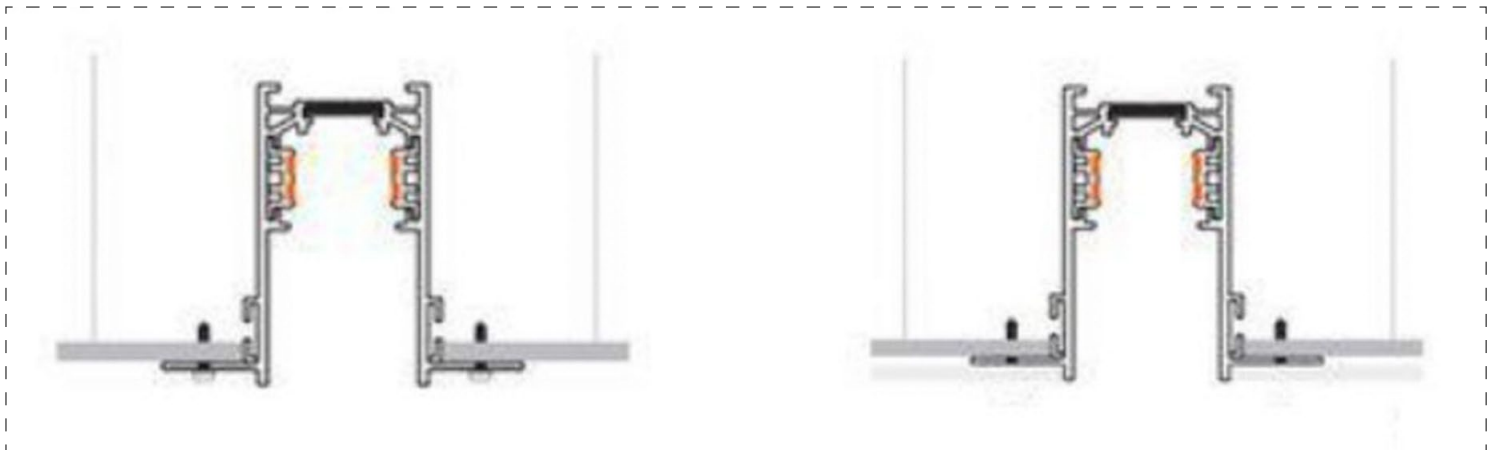

Instalação de carril integrado/Trimless

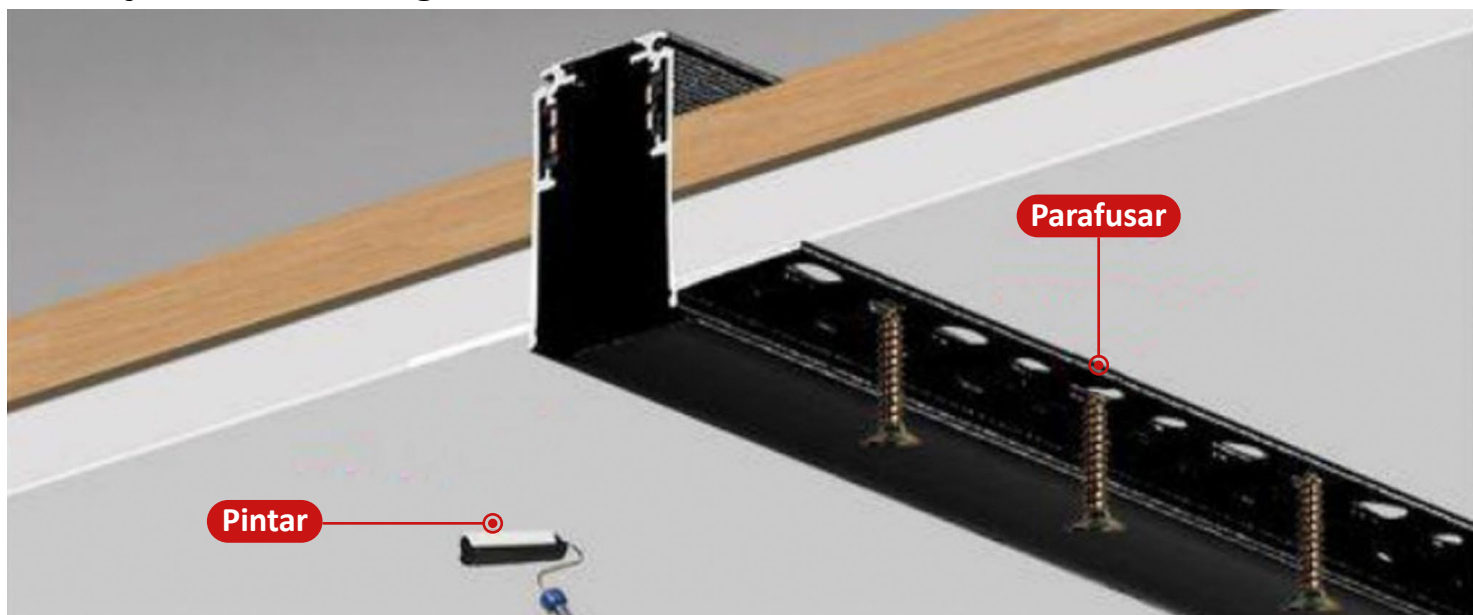

- 1 Realizar um furo no gesso de pelo menos 30mm de largura. Leve em consideração que deve existir um espaço mínimo de 5,5cm entre o teto ou parede e o gesso acartonado.

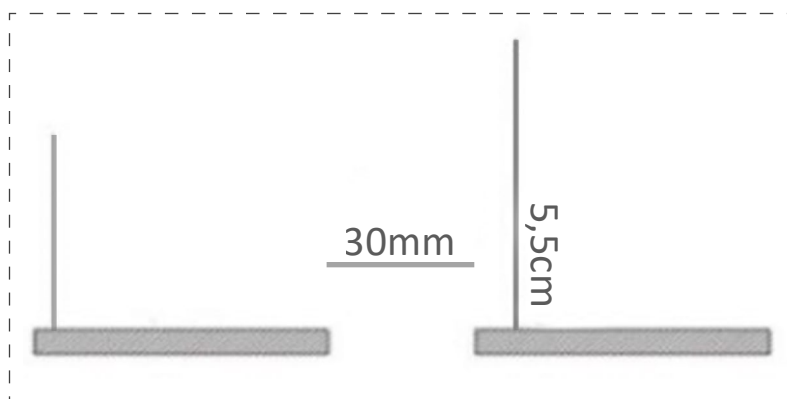

- 2 Colocar o carril no furo e aparafusá-lo até que esteja firmemente ajustado. Em seguida, colocar a massa de fixação ou juntas, lixar e pintar.

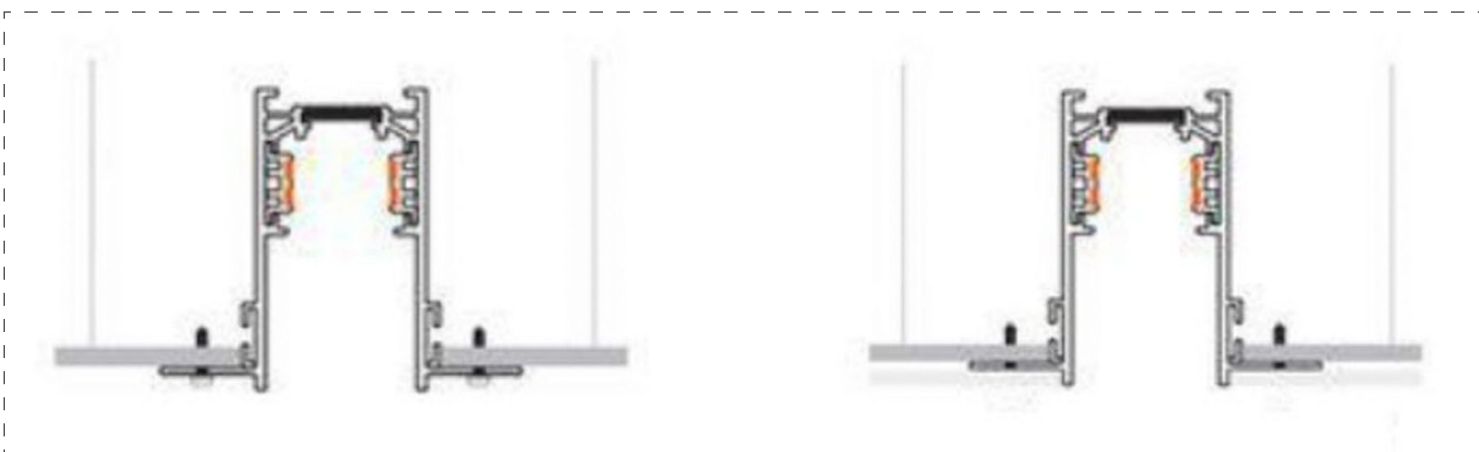

Installazione Binario - Incasso a Scomparsa

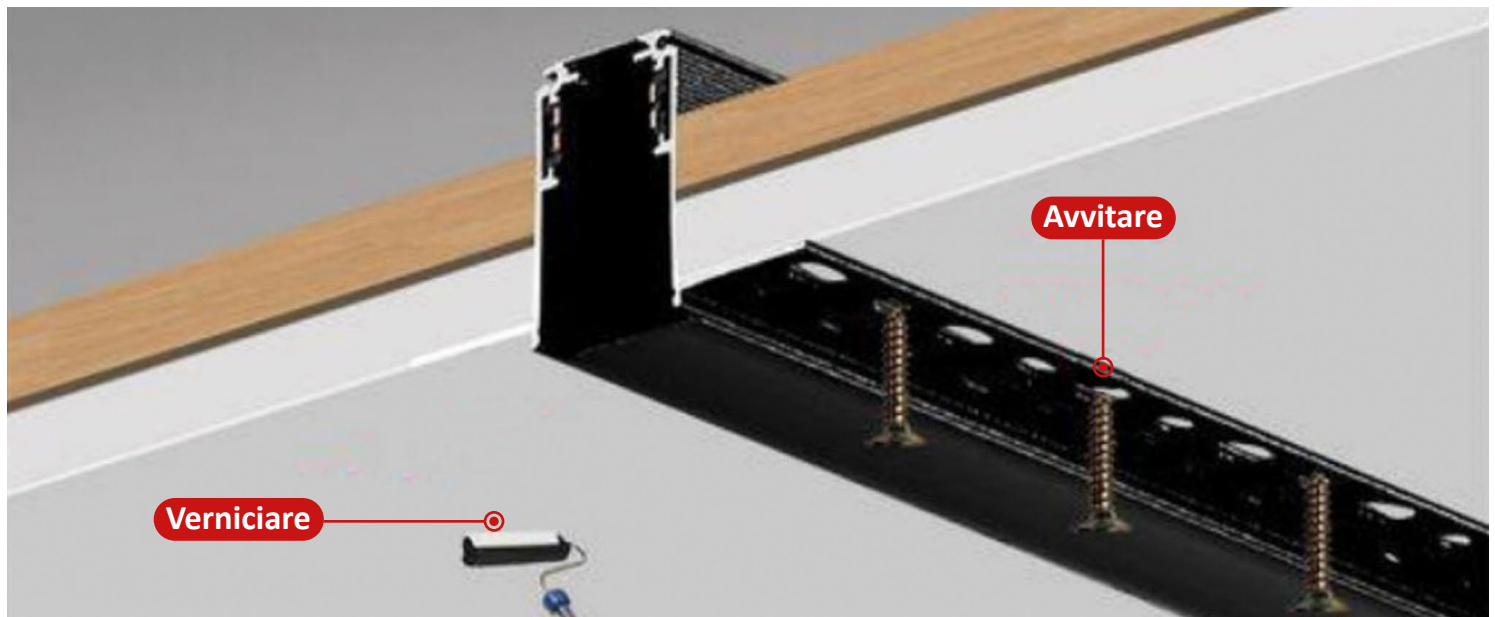

- 1 Praticare un foro nel cartongesso di almeno 30mm di larghezza. È necessario uno spazio minimo di 5,5cm tra il soffitto/la parete e il cartongesso.

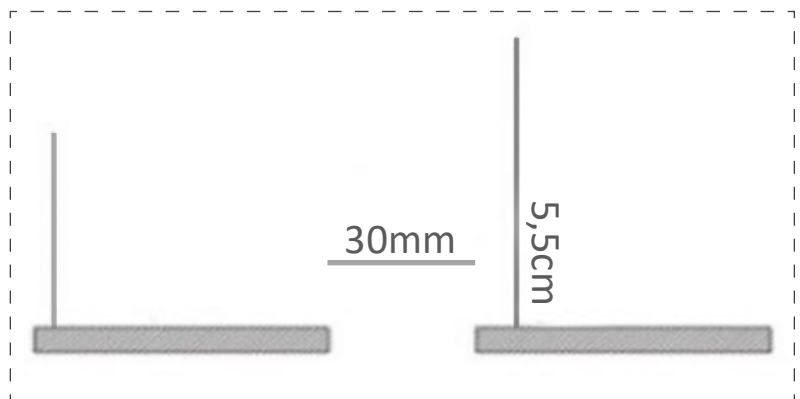

- 2 Posizionare il binario nel foro e avvitare fino a serrare saldamente. Quindi applicare il sigillante o la pasta per giunti carteggiare e verniciare.

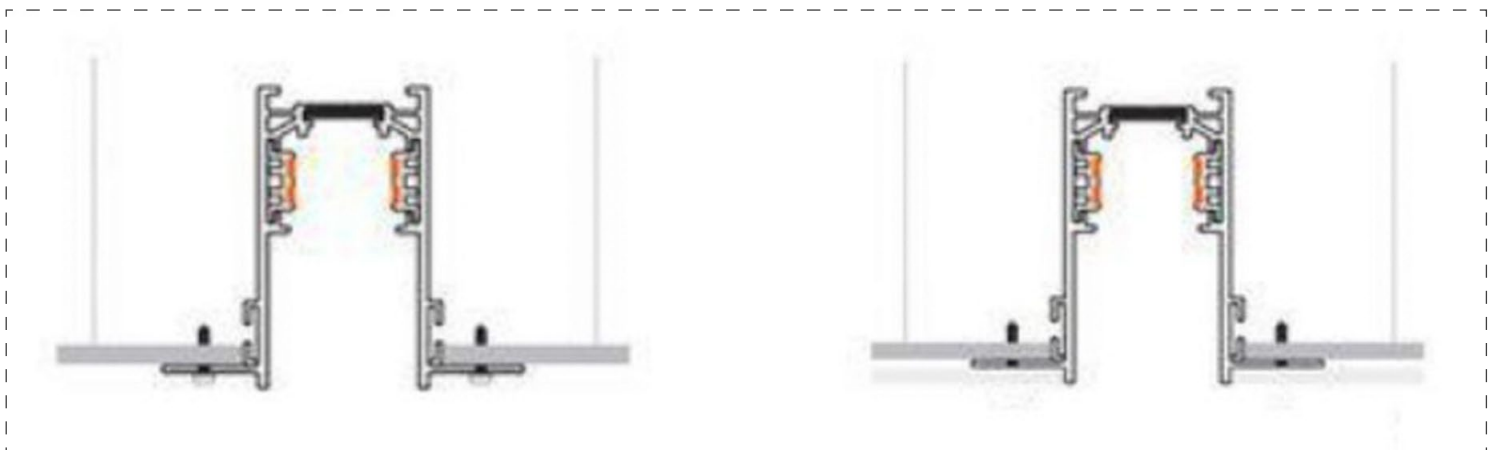

Schiene Trimless-Montage

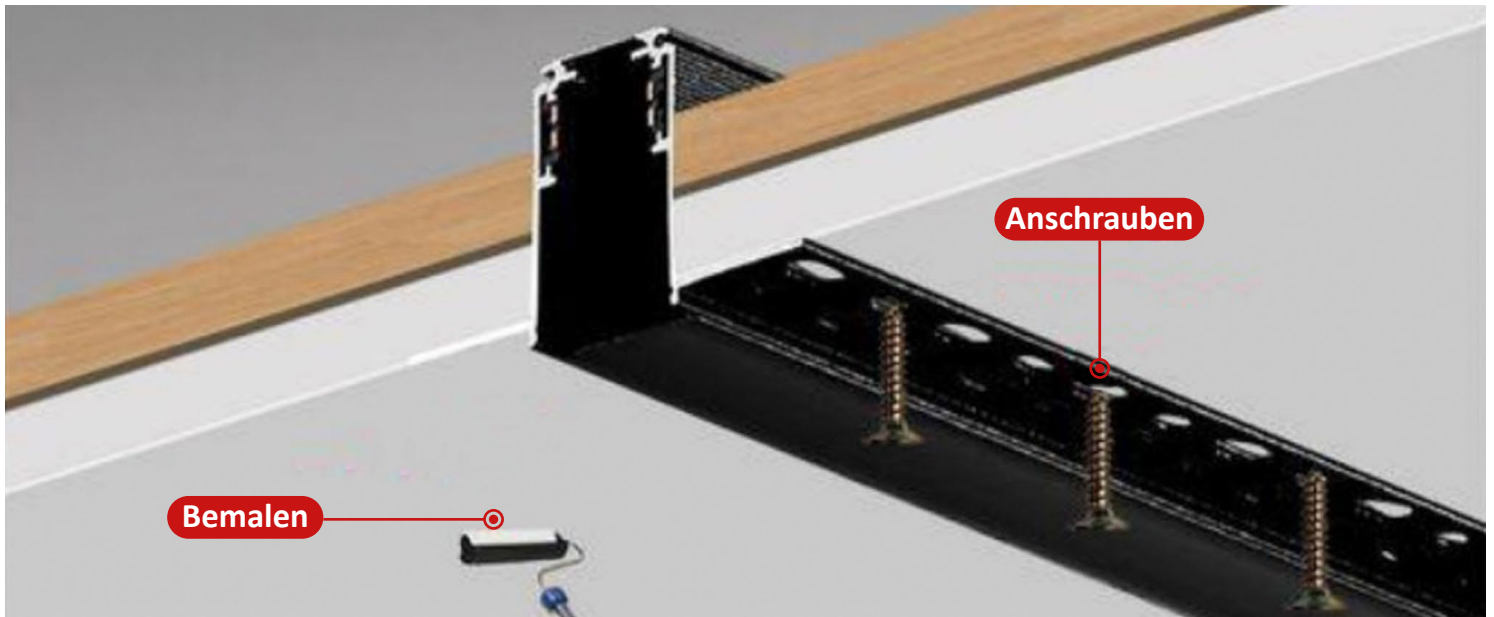

- 1 Einen min. 30mm breiten Hohlraum in die Gipskartonplatte machen. Bitte beachten: Zwischen Decke / Wand und Platte muss ein Mindestabstand von 5,5cm bestehen.

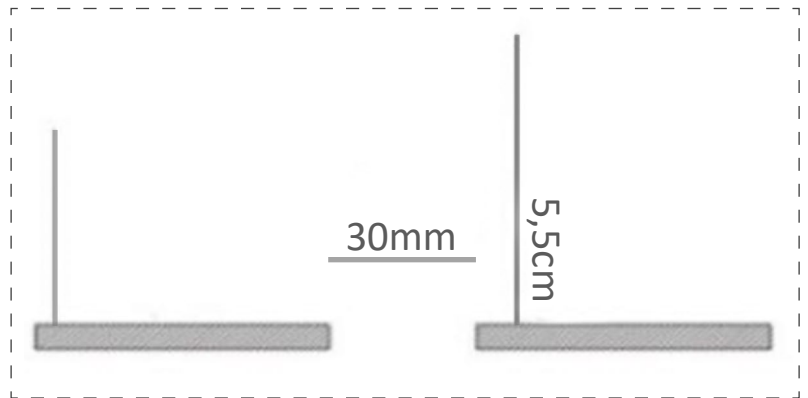

- 2 Schiene in den Hohlraum einlegen. Mit Schrauben befestigen. Hohlraum mit Spachtelmasse füllen. Abschleifen und bemalen.

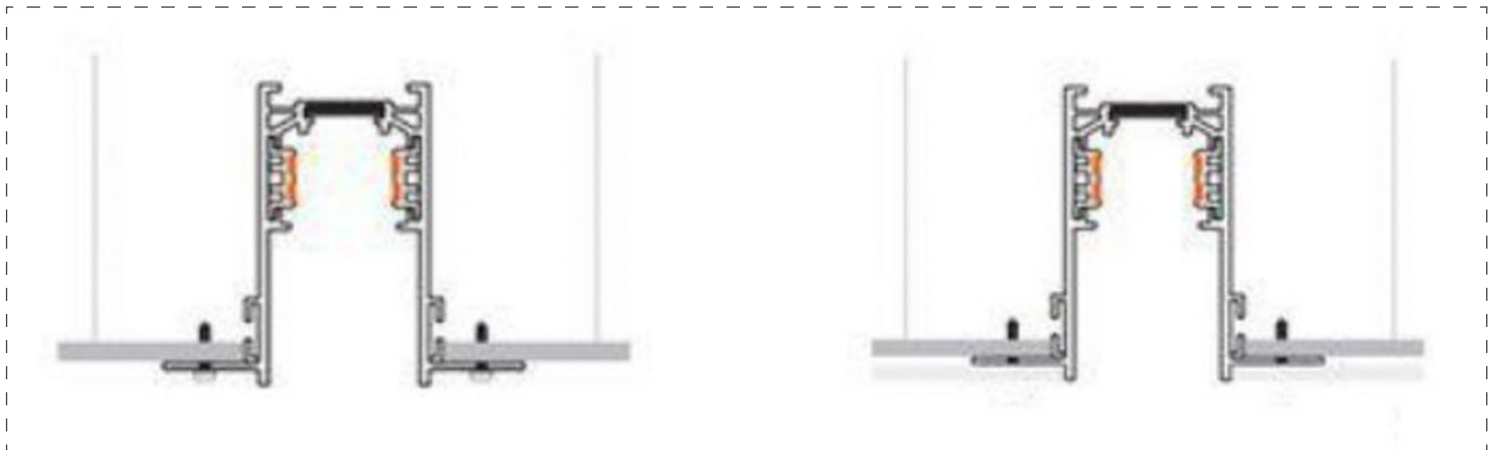

Recessed Installation (Paint type)

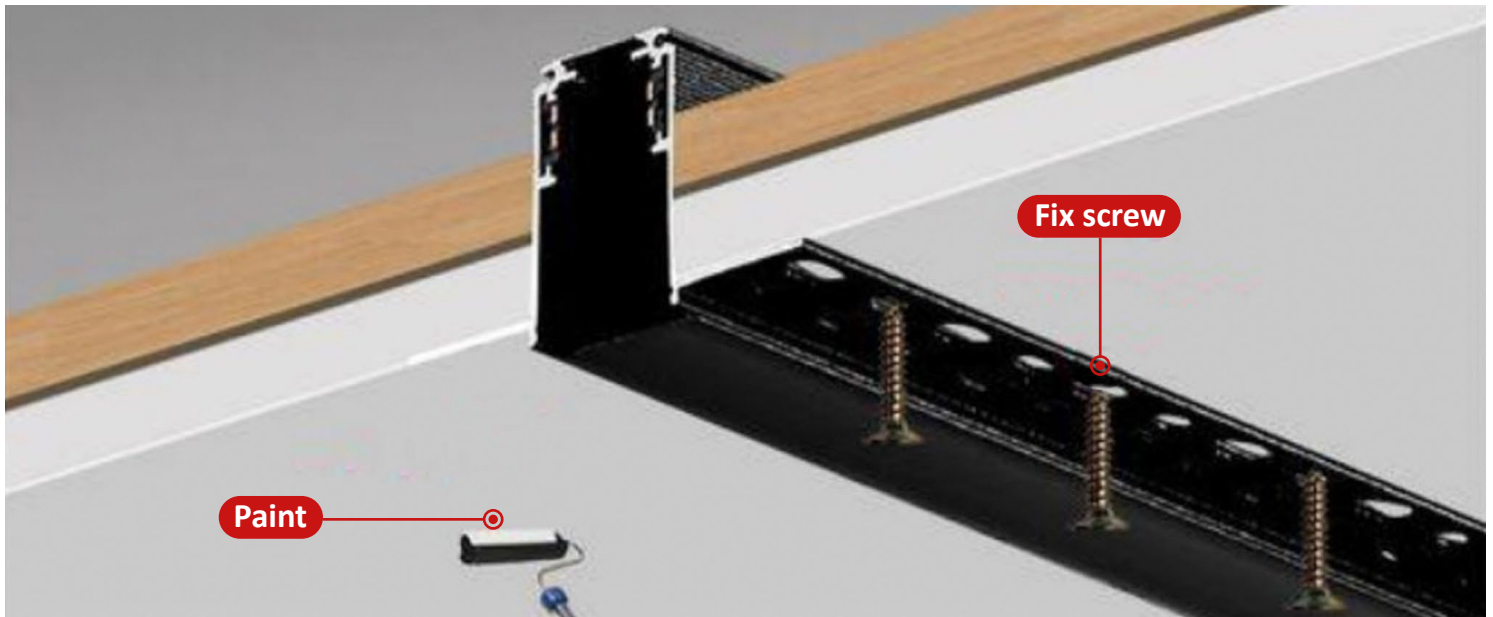

- 1 Open a hole onto the ceiling of at least 30mm wide. Make sure that the distance between the ceiling and the roof is at least 5,5cm.

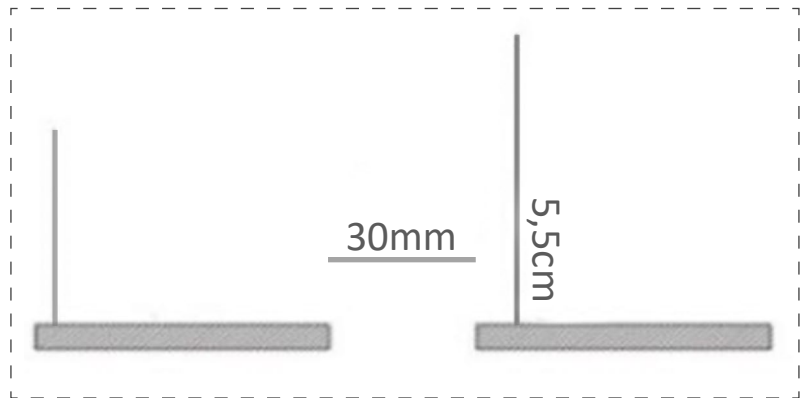

- 2 Put the track into the hole and fix it with screws. Then paint the surface.

